

NOTE:

- MECHANICAL PERFORMANCE:
  - 1-1.INSERTION FORCE: 0.5~2.0kgf.
  - 1-2.REMOVAL FORCE: 0.8kgf~2.0kgf.
  - 1-3.DURABILITY: 10000 CYCLES.
- ELECTRICAL PERFORMANCE:
  - 2-1. CURRENT RATING:3.0A  
VOLTAGE RATING:5.0V
  - 2-2. LLCR: VBUS & GND PINS AND OTHER PINS: 40mA/PIN MAX.  
SHIELD: 50mA/MAX.  
LLCR MAX. CHANGE OF ALL PINS: 10mA.
  - 2-3.INSULATION RESISTANCE: 100MΩ MIN
  - 2-4.DIELECTRIC WITHSTAND VOLTAGE,AC 100V FOR 1 MINUTE.
- ENVIRONMENTAL PERFORMANCE:
  - OPERATING TEMPERATURE: -25°C~+85°C.
- IR REFLOW:
  - THE PEAK TEMPERATURE ON THE BOARD SHALL BE MAINTAINED FOR 10 SECONDS AT 260°C.

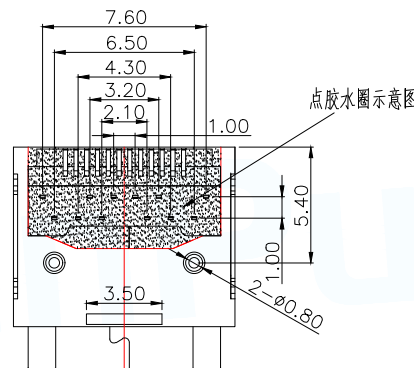

A1	GND	B12	GND
A2	SSTXP1	B11	SSTXP1
A3	SSTXN1	B10	SSTXN1
A4	VBUS	B09	VBUS
A5	CC1	B08	VBUS
A6	DP1	B07	DN2
A7	DN1	B06	DP2
A8	SBU1	B05	CC2
A9	VBUS	B04	VBUS
A10	SSRXN2	B03	SSRXN2
A11	SSRXP2	B02	SSRXP2
A12	GND	B01	GND
PIN	SIGNAL NAME	PIN	SIGNAL NAME

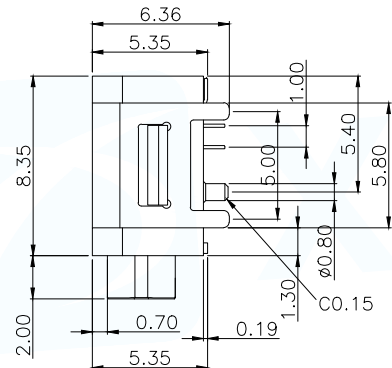
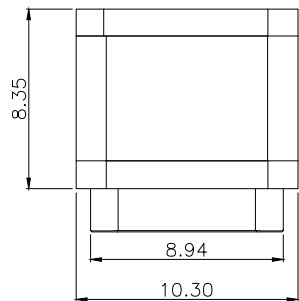
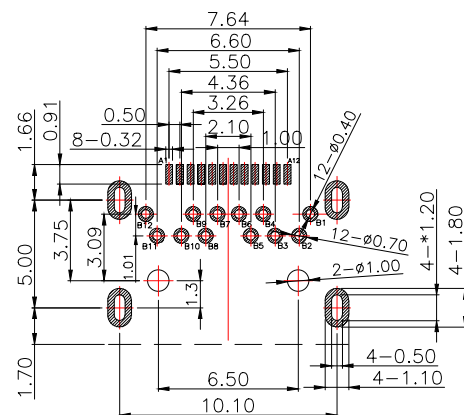
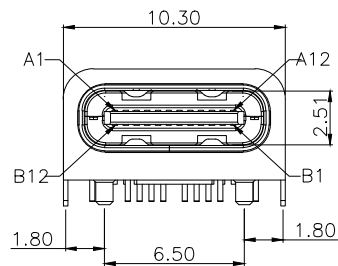

RECOMMENDED PCB LAYOUT  
Tolerance:±0.05mm

NO	DESCRIPTION	QTY	MATERIAL	REMARKS	
1	Rear high	1PCS	PA10T	BLACK	
2	SHELL HOUSING	1PCS	PA10T	BLACK	
3	CONTACT	1SET	C7025	接触, SMT 1u"	
4	Bracket	1PCS	STAINLESS STEEL	镀镍 30u"	
5	SHELL	1PCS	STAINLESS STEEL	镀镍 30u"	
6	Middle clip	1PCS	STAINLESS STEEL	Cleaning	
7	Run-RING	1PCS	Silica gel	BLACK	
MANUFACTURE DWG			东莞市讯普电子科技有限公司 DongGuan XunPu Electronics Co.,Ltd		
UNLESS OTHERWISE SPECIFIED TOLERANCES				TITLE: TYPE-C 24pin 四脚插板防水成品图	
DECIMALS:				PAR	TYPEC-508DDW-ACP24X7
ANGLES:				DWN	
.X:±0.25 X':±2'				CHKD	
.XX:±0.15 X.X':±0.5'			APVD		
.XXX:±0.10			SCALE:1:1	UNIT:MM	
			CUSTOMER COPY	SIZE:A4	
				SHEET:1F1	
				REV:A	